

Escape ESCS6042SKTF 60" x 42" x 22"

PRODUCT NUMBER: ESCS6042SKTF-LH & ESCS6042SKTF-RH 

COMBINATION SILVER SERIES

Hydro Massage
Your Health ... Our Passion

TECHNICAL SPECIFICATIONS	
Drain	End drain
Pump Configuration: Select 2	Std. = Standard / Alt LF/RF Optional
Bath Weight (empty)	175 lbs
Gallons to Operate	50-68
ELECTRICAL SPECIFICATIONS	
Motor/Pump	(2) 115v 20AMP GFCI Circuits
Inline Stainless Steel Heater	(Opt.) 115v 20AMP GFCI Circuit

BATHERS: 1	
INSTALLATION	
	DECK (D)
	UNDER MOUNT (U)
•	ALCOVE (A)
	FREESTANDING (F)
	CLAWFOOT (L)
	PEDESTAL (P)

Jet & Control placement may vary





Integral Skirt w/ velcro access panel and tile flange



STANDARD FEATURES & ACCESSORIES for COMBINATION SILVER SERIES BATHS _____

JETS

21 Air & Water Massage Jets
Accumassage Back, Neck Jets
Ultra Flow Jets 
Micro Flow Jets 
Classic Air Jets 

PUMPS

2.25 Hydropower 1-speed Pump
1.0 Air Power 3-Speed Warm Air Pump
Quiet Pad Anti-Vibration Mounted Pump

CONTROLS

Air Switch On/Off Control(s)
Automatic Purge & Dry Cycle Control

PURITY

HydroClean Water Purity System
HydroCleanse

STANDARD ACCESSORIES

Mood Light
Lift & Turn Drain - White, Biscuit, Bone, Brushed Nickel, Oil Rubbed Bronze, Polished Chrome
Deluxe Cushion Pillow
Integral Tile Flange
EZ Level Adjustable Legs
FDA Recipe Non-Toxic Food & Beverage Grade Plumbing (primarily)
30 Point Quality Assurance Factory Test

REQUIREMENTS

Pump Locations: Select 2
Electrical: two 115v 20amp GFCI Circuits
Tub should not be supported by the lip in any way. Level tub & screw or glue EZ Level adjustable legs to sub floor.

CUT OUT DIMENSIONS:

OVALS: A template will be provided
RECTANGLES: Subtract 1" to 1.5" from length & width for hole cut out size

EZ CLEAN CAST ACRYLIC LIMITED LIFETIME WARRANTY 

OPTIONAL FEATURES & ACCESSORIES

(Please type in the box below)

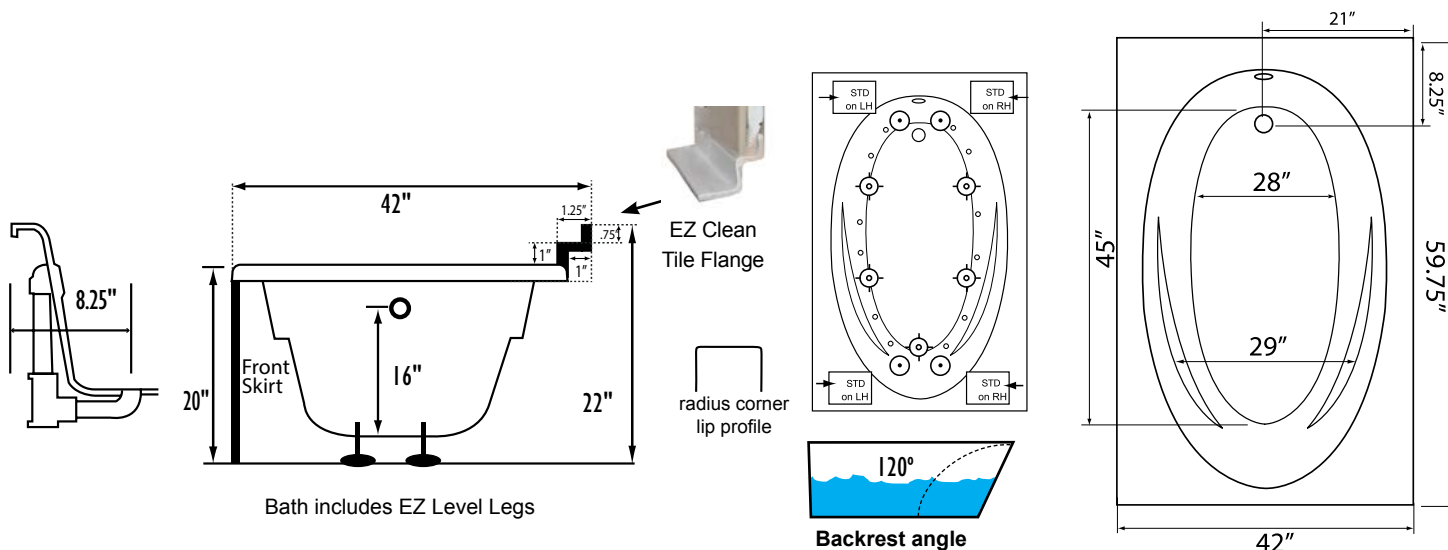

Some standard & most alternate pump locations may stickout past perimeter of the bath 1"-3". NOTE: Graphics may not be to scale. Specifications and features are subject to change without notice and are ± .25". All final measurements should be taken from tub on site. Access 18"x 18" or larger is required for each pump. Consult your contractor for installation requirements.