

Maya 4242 | Air A18 Massage Series

Product Number: MAA18J4242SDFS-A 42" x 42" x 34"



STANDARD & OPTIONAL ACCESSORIES

JETS: 18 Total

X 18 EZ Clean HTT Air Jets

PUMPS ❖

1.25 Air Power Variable Speed, Pulse & Wave Heated Air Pump
Quiet Pad Anti-Vibration Mounted Pumps

HEATERS

Heated Air Pump
Warm Back Rest Tubing Zone

CONTROLS

Air Switch On/Off Control(s) for Mood Light
Variable Speed Air Massage Control Automatic Purge & Dry
Cycle Control

PURITY

HydroCleanse

DRAINS & OVERFLOWS INFORMATION

- Overflow: Cable or Lift and Turn: Included- Polished Chrome.
Optional-White, Biscuit, Black, Brushed Nickel, Polished Nickel, Oil Rubbed Bronze.
- Bath Drain: Cable or Lift and Turn: Included- Polished Chrome.
Optional-White, Biscuit, Black, Brushed Nickel, Polished Nickel, Oil Rubbed Bronze.
- In Floor Drain EZ Fast Connect (*optional*)

FAUCET INFORMATION

- Deck Mount or Floor mount
- Access Panel required for Deck faucet (*optional*)
- Floor mount verify spout distance

STANDARD ACCESSORIES

Mood Light • Deluxe Cushion Pillow • EZ Level Base • FDA
Recipe Non-Toxic Food & Beverage Grade
Plumbing (primarily) • 30 Point Quality Assurance Factory Test



TECHNICAL SPECIFICATIONS

Side drain
Pump Location: Standard

ELECTRICAL REQUIREMENTS

(1) 115v 20AMP GFCI Circuits



❖ Equipment Access Panel

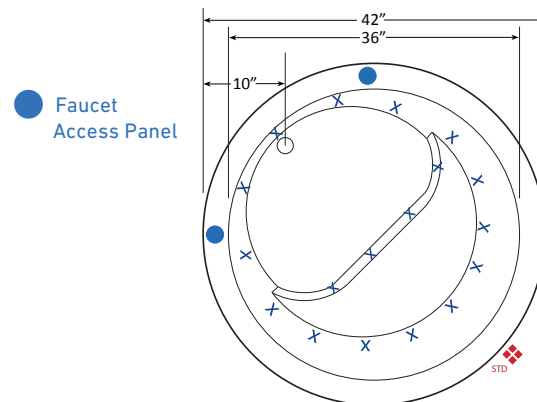

● Faucet Access Panel

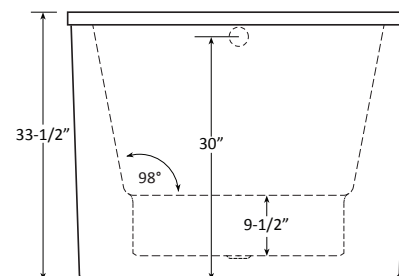

Specifications and features are subject to change without notice and are + .25". All final measurements should be taken from tub on site.
HydroMassage Products LLC • 303-341-1845 • Fax: 303-342-1850 • www.hydrmassageproducts.com