

Maya 4242 | H15 Water Massage Series

Product Number: MAH15J4242SDFS-A 42" x 42" x 34"



STANDARD & OPTIONAL ACCESSORIES

JETS: 15 Total

- 2 AccuMassage Neck Water Jets
- 7 AccuMassage Back Jets
- 2 Sole Soother Foot Jets
- 4 Ultra Flow Water Jets

PUMPS

2 - 2.25 Hydropower 3-Speed Pumps
Quiet Pad Anti-Vibration Mounted Pumps

HEATERS

Stainless Steel Electric Heater

CONTROLS

Air Switch On/Off Control(s) for Hydro Pump & Chromatherapy
3-speed Massage: High, medium, low

PURITY

Hydro Clean Water Purity System • HydroCleanse

DRAINS & OVERFLOWS INFORMATION

- Overflow: Cable or Lift and Turn: Included- Polished Chrome.
Optional- White, Biscuit, Black, Brushed Nickel, Polished Nickel, Oil Rubbed Bronze.
- Bath Drain: Cable or Lift and Turn: Included- Polished Chrome.
Optional- White, Biscuit, Black, Brushed Nickel, Polished Nickel, Oil Rubbed Bronze.
- In Floor Drain EZ Fast Connect (**optional**)

FAUCET INFORMATION

- Deck Mount or Floor mount (not included)
- Access Panel required for Deck faucet (**optional**)
- Floor mount verify spout distance

STANDARD ACCESSORIES

Chromatherapy Lighting • Deluxe Cushion Pillow • EZ Level Base • FDA Recipe Non-Toxic Food & Beverage Grade Plumbing (primarily) • 30 Point Quality Assurance Factory Test



TECHNICAL SPECIFICATIONS

Side drain
Pump Location: Standard

ELECTRICAL REQUIREMENTS

(3) - 115v 20AMP GFCI Circuits



Equipment Access Panel

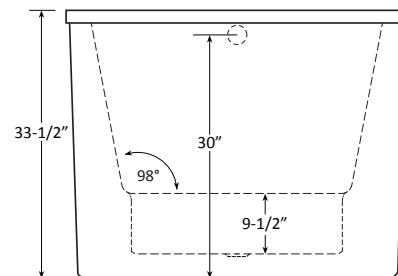
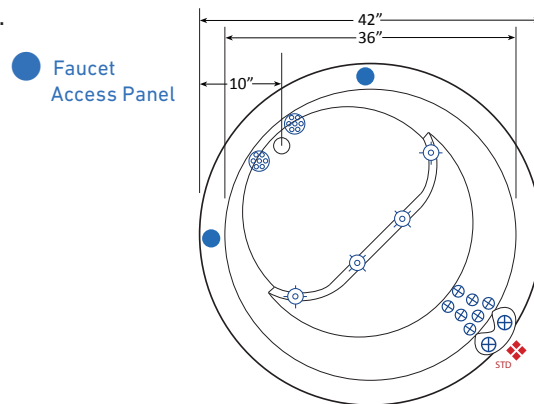

Specifications and features are subject to change without notice and are + .25". All final measurements should be taken from tub on site.

HydroMassage Products LLC • 303-341-1845 • Fax: 303-342-1850 • www.hydrmassageproducts.com