

Maya 4242 | H9 Water Massage Series

Product Number: MAH9J4242SDFS-A 42" x 42" x 34"



STANDARD & OPTIONAL ACCESSORIES

JETS: 9 Total

- 5 Ultra Flow Water Jets
- 4 Micro Flow Water Massage Jets

PUMPS

2.25 Hydropower 1- Speed Pump
Quiet Pad Anti-Vibration Mounted Pumps

CONTROLS

Air Switch On/Off Control(s) for Hydro Pump

PURITY

HydroCleanse

DRAINS & OVERFLOWS INFORMATION

- Overflow: Cable or Lift and Turn: Included- Polished Chrome.
Optional - White, Biscuit, Black, Brushed Nickel, Polished Nickel, Oil Rubbed Bronze.
- Bath Drain: Cable or Lift and Turn: Included- Polished Chrome.
Optional - White, Biscuit, Black, Brushed Nickel, Polished Nickel, Oil Rubbed Bronze.
- In Floor Drain EZ Fast Connect (**optional**)

FAUCET INFORMATION

- Deck Mount or Floor mount (not included)
- Access Panel required for Deck faucet (**optional**)
- Floor mount verify spout distance

STANDARD ACCESSORIES

EZ Level Base • FDA Recipe Non-Toxic Food & Beverage Grade Plumbing (primarily) • 30 Point Quality Assurance Factory Test



TECHNICAL SPECIFICATIONS

Side drain
Pump Location: Standard

ELECTRICAL REQUIREMENTS

(1) - 115v 20AMP GFCI Circuits



Equipment Access Panel

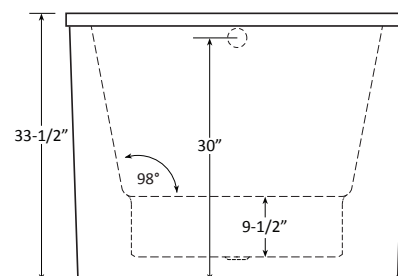
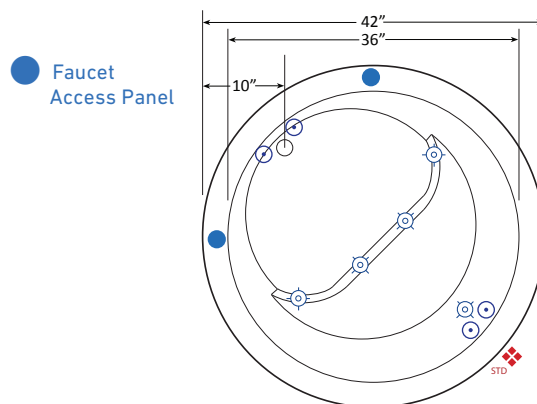

Specifications and features are subject to change without notice and are + .25". All final measurements should be taken from tub on site.

HydroMassage Products LLC • 303-341-1845 • Fax: 303-342-1850 • www.hydrmassageproducts.com