

Oasis 6640CD | Air A12 Massage Series

Product Number: OAA12J6640CDFS-A 66" x 40" x 24"



STANDARD & OPTIONAL ACCESSORIES

JETS: 12 Total

- 12 Classic Air Jets

PUMPS

1.0 Air Power 3-speed heated Air Pump
Quiet Pad Anti-Vibration Mounted Pump

CONTROLS

Air Switch On/Off Control(s)
Automatic Purge & Dry Cycle Control

PURITY

HydroCleanse

DRAINS & OVERFLOWS INFORMATION

- Overflow: Integral Round: Included- Polished Chrome or Brushed Nickel.
Optional - White, Biscuit, Black, Polished Nickel, Oil Rubbed Bronze.
- Bath Drain: Pop up: Included- Polished Chrome or Brushed Nickel.
Optional - White, Biscuit, Black, Polished Nickel, Oil Rubbed Bronze.
- In Floor Drain EZ Fast Connect (*optional*)

FAUCET INFORMATION

- Floor mount (not included)
- Floor mount verify spout distance

STANDARD ACCESSORIES

EZ Level Base • FDA Recipe Non-Toxic Food & Beverage Grade Plumbing (primarily) • 30 Point Quality Assurance Factory Test

ADDITIONAL INFORMATION

6" or more space required to access equipment panel. Tub may also need to be shifted or disconnected in some situations.

Access panel equipment design and location may vary based on model.

Your licensed installer must water test and run all equipment before leaving your home to ensure proper operation and validate warranty.



TECHNICAL SPECIFICATIONS

Center drain
Pump Location(s): Standard

ELECTRICAL REQUIREMENTS

(1) 115v 20AMP GFCI Circuits

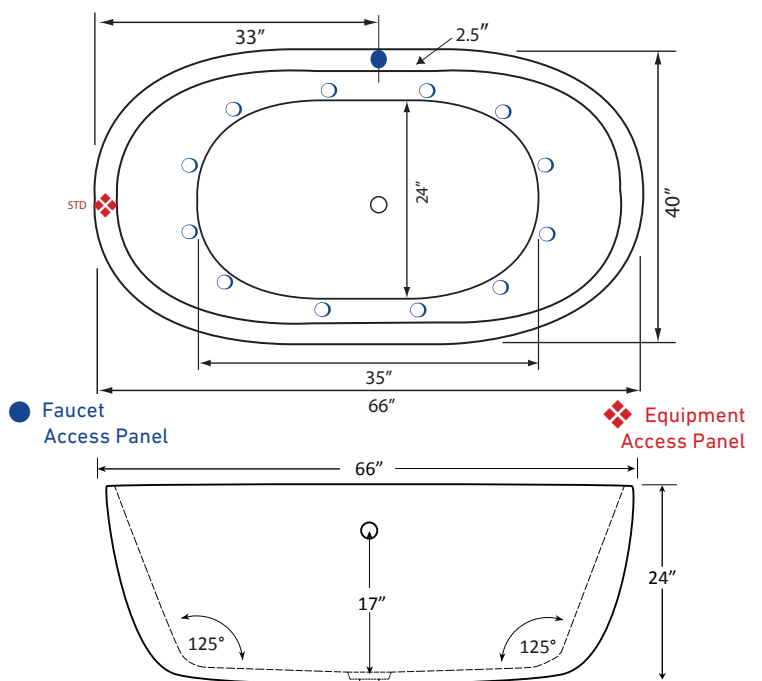

Specifications and features are subject to change without notice and are + .25". All final measurements should be taken from tub on site.

HydroMassage Products LLC • 303-341-1845 • Fax: 303-341-1850 • www.hydromassageproducts.com