

Reward 6636CD | Air A18 Massage Series

Product Number: REA18J6636CDFS-A 66" x 36" x 25"



STANDARD & OPTIONAL ACCESSORIES

JETS: 18 Total

- X 18 EZ Clean HTT Air Jets

PUMPS

1.25 Air Power Variable Speed, Pulse & Wave Heated Air Pump
Quiet Pad Anti-Vibration Mounted Pumps

HEATERS

Heated Air Pump • Warm Back Rest Tubing Zone

CONTROLS

Air Switch On/Off Control(s) for Underwater Light
Variable Speed Air Massage Control
Automatic Purge & Dry Cycle Control

PURITY

HydroCleanse

DRAINS & OVERFLOWS INFORMATION

- Overflow: Integral Slotted in Acrylic - no finishes available.
- Bath Drain: Pop up: Included- Polished Chrome or Brushed Nickel.
Optional - White, Biscuit, Black, Polished Nickel, Oil Rubbed Bronze.
- In Floor Drain EZ Fast Connect (*optional*)

FAUCET INFORMATION

- Deck Mount or Floor mount (not included & no faucet holes drilled)
- Access Panel recommended for Deck faucet (*optional*)
- Floor mount verify spout distance

STANDARD ACCESSORIES

Underwater Light • Deluxe Cushion Pillow • EZ Level Base
• FDA Recipe Non-Toxic Food & Beverage Grade Plumbing (primarily) • 30 Point Quality Assurance Factory Test

ADDITIONAL INFORMATION

6 1/2" or more space required to access equipment panel. Tub may also need to be shifted or disconnected in some situations.

Access panel equipment design and location may vary based on model.

Your qualified installer must water test and run all equipment before leaving your home to ensure proper operation and validate warranty.



TECHNICAL SPECIFICATIONS

Center drain
Pump Location(s): Standard or RF #2

ELECTRICAL REQUIREMENTS

(1) 115v 20AMP GFCI Circuits

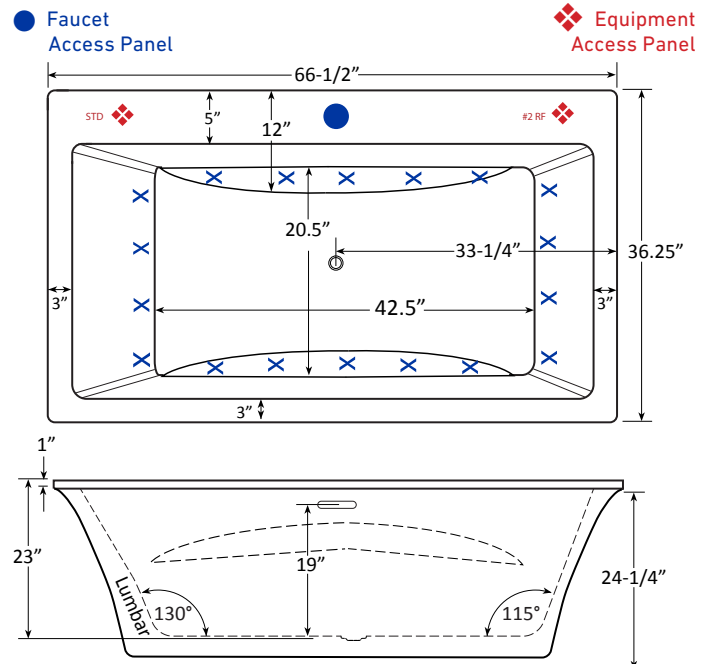

Specifications and features are subject to change without notice and are + .25". All final measurements should be taken from tub on site.

HydroMassage Products LLC • 303-341-1845 • Fax: 303-341-1850 • www.hydromassageproducts.com