

# Rosabella 7236SD | Air A12 Massage

Product Number: ROA12J7236SDFS-A 72" x 36" x 28"



## STANDARD & OPTIONAL ACCESSORIES

### JETS: 12 Total

- 12 Classic Air Jets

### PUMPS ❖

1.0 Air Power 3-Speed, Warm Air Pump  
Quiet Pad Anti-Vibration Mounted Pump

### CONTROLS

Air Switch On/Off Control(s) for Heat Pump  
Automatic Purge & Dry Cycle Control

### PURITY

HydroCleanse

### DRAINS & OVERFLOWS INFORMATION

- Overflow: Integral Slotted in Acrylic – no finishes available
- Bath Drain: Pop up: Included - Polished Chrome or Brushed Nickel  
Optional: White, Biscuit, Black, Polished Nickel, Oil Rubbed Bronze
- In Floor Drain EZ Fast Connect (optional)

### FAUCET INFORMATION

- Deck Mount or Floor mount (not included & no faucet holes drilled)
- Access Panel recommended for Deck faucet (optional)
- Floor mount verify spout distance

### STANDARD ACCESSORIES

FDA Recipe Non-Toxic Food & Beverage Grade Plumbing (primarily) • 30 Point Quality Assurance Factory Test

### ADDITIONAL INFORMATION

3" or more space required to access equipment panel. Tub may also need to be shifted or disconnected in some situations.

Access panel equipment design and location may vary based on model.

Your qualified installer must water test and run all equipment before leaving your home to ensure proper operation and validate warranty.



### TECHNICAL SPECIFICATIONS

Side drain  
Pump Location(s): Standard or #2RF

### ELECTRICAL REQUIREMENTS

(1) 115v 20AMP GFCI Circuits



● Faucet Access Panel

❖ Equipment Access Panel

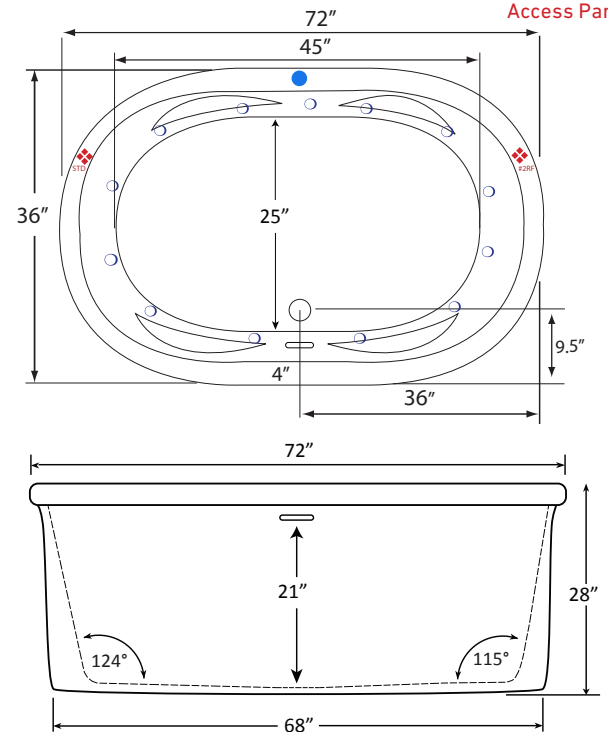

Specifications and features are subject to change without notice and are + .25". All final measurements should be taken from tub on site.

HydroMassage Products LLC • 303-341-1845 • Fax: 303-341-1850 • [www.hydromassageproducts.com](http://www.hydromassageproducts.com)