

# Rosabella 7236SD | Air A34 Massage

Product Number: ROA34J7236SDFS-A 72" x 36" x 28"



## STANDARD & OPTIONAL ACCESSORIES

### JETS: 34 Total

- X 18 EZ Clean HTT Air Leg Jets
- X 6 EZ Clean HTT Air Back Jets
- X 10 EZ Clean HTT Leg Therapy Air Massage Floor Jets

### PUMPS

1.25 Air Power Variable Speed, Pulse & Wave Heated Air Pump  
Quiet Pad Anti-Vibration Mounted Pumps

### HEATERS

Whisper Flo Heat System  
Warm Back Rest Tubing Zone

### CONTROLS

Air Switch On/Off Control(s) for Chromatherapy Lighting  
Variable Speed Air Massage control  
Automatic Purge & Dry Cycle Control

### PURITY

HydroCleanse

### DRAINS & OVERFLOWS INFORMATION

- Overflow: Integral Slotted in Acrylic – no finishes available
- Bath Drain: Pop up: Included - Polished Chrome or Brushed Nickel  
Optional: White, Biscuit, Black, Polished Nickel, Oil Rubbed Bronze
- In Floor Drain EZ Fast Connect (optional)

### FAUCET INFORMATION

- Deck Mount or Floor mount (not included & no faucet holes drilled)
- Access Panel recommended for Deck faucet (optional)
- Floor mount verify spout distance

### STANDARD ACCESSORIES

Grab Bar(s): One - White, Biscuit, Bone, Brushed Nickel, Polished Chrome, Oil Rubbed Bronze

Chromatherapy Lighting • Deluxe Cushion Pillow • EZ Level Base •  
FDA Recipe Non-Toxic Food & Beverage Grade  
Plumbing (primarily) • 30 Point Quality Assurance Factory Test

### ADDITIONAL INFORMATION

3" or more space required to access equipment panel. Tub may also need to be shifted or disconnected in some situations.

Access panel equipment design and location may vary based on model.

Your qualified installer must water test and run all equipment before leaving your home to ensure proper operation and validate warranty.



### TECHNICAL SPECIFICATIONS

Side drain  
Pump Location(s): Standard or #2RF

### ELECTRICAL REQUIREMENTS

(2) 115v 20AMP GFCI Circuits



Faucet Access Panel

Equipment Access Panel

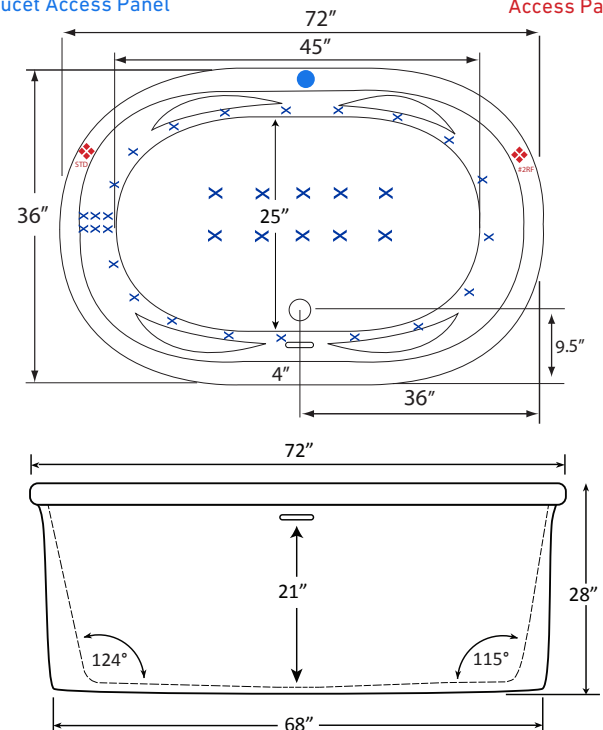

Specifications and features are subject to change without notice and are + .25". All final measurements should be taken from tub on site.

HydroMassage Products LLC • 303-341-1845 • Fax: 303-341-1850 • www.hydromassageproducts.com

