

# Rosabella 7236SD Drop In Bath | Air A34 Massage

Product Number: ROA34J7236SD 72" x 36" x 27"



## STANDARD & OPTIONAL ACCESSORIES

### JETS: 34 Total

- X** 18 EZ Clean HTT Air Leg Jets
- X** 6 EZ Clean HTT Air Back Jets
- X** 10 EZ Clean HTT Leg Therapy Air Massage Floor Jets

### PUMPS

1.25 Air Power Variable Speed, Pulse & Wave Heated Air Pump  
Quiet Pad Anti-Vibration Mounted Pumps

### HEATERS

Whisper Flo Heat System  
Warm Back Rest Tubing Zone

### CONTROLS

Air Switch On/Off Control(s) for Chromatherapy Lighting  
Variable Speed Air Massage control  
Automatic Purge & Dry Cycle Control

### PURITY

HydroCleanse

### DRAINS & OVERFLOWS INFORMATION

- Overflow: Integral Slotted in Acrylic – no finishes available
- Bath Drain: Pop up: Included - Polished Chrome or Brushed Nickel  
**Optional:** White, Biscuit, Black, Polished Nickel, Oil Rubbed Bronze
- In Floor Drain EZ Fast Connect (**optional**)

### FAUCET INFORMATION

- Note: Faucet Deck on the technical drawing for reference.

### STANDARD ACCESSORIES

EZ Level Base • FDA Recipe Non-Toxic Food & Beverage Grade Plumbing (primarily) • 30 Point Quality Assurance Factory Test

### ADDITIONAL INFORMATION

Your qualified installer must water test and run all equipment before leaving your home to ensure proper operation and validate warranty.

### TECHNICAL SPECIFICATIONS

Side drain  
Select Pump Location(s): Standard, LR#2, RR#3 or RF#4

### ELECTRICAL REQUIREMENTS

(2) 115v 20AMP GFCI Circuits

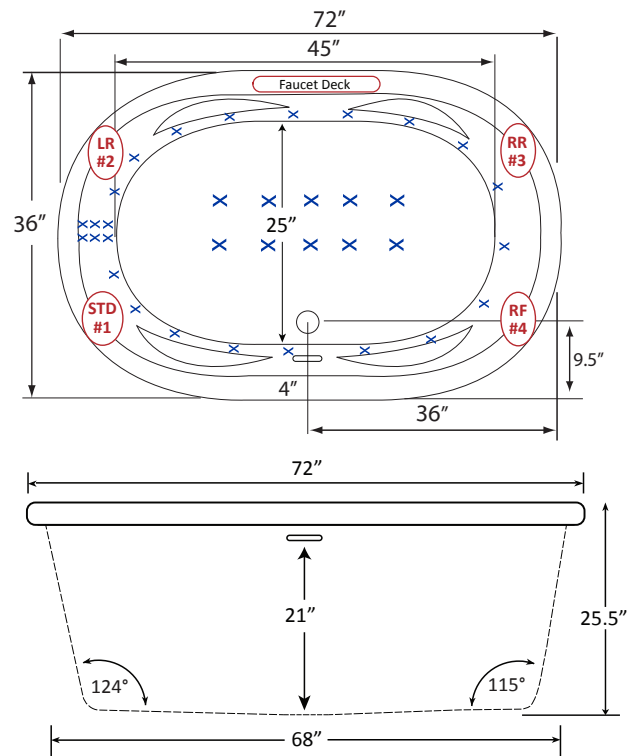

Specifications and features are subject to change without notice and are + .25". All final measurements should be taken from tub on site.

HydroMassage Products LLC • 303-341-1845 • Fax: 303-341-1850 • [www.hydromassageproducts.com](http://www.hydromassageproducts.com)